

There is often confusion regarding VFF476 Fuel Filter fitted to vehicles using the PSA 1.6 HDI engine as it is sometimes seen as not being the same as the filter removed from the vehicle.

This is due to the technician not realising that the water heater module **(4)** has to be carefully removed from the old filter **(1)** and fitted on the new filter using the two new O rings **(6)** supplied.

In addition if the filter is an early type it previously had the "water in fuel" sensor built into the filter but following a production modification this is now supplied as a separate part item **(5)** below. In the event that a filter is removed from an early vehicle without the separate sensor it will be necessary to obtain this part number 191311 from a Peugeot/Citroen dealer.

Please note that when fitting this sensor it is designed to break through the blanking plug at the bottom of the sensor location on the filter.

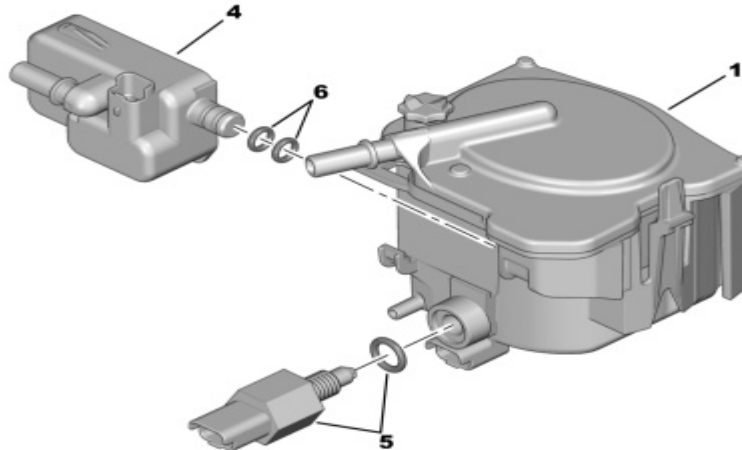

Thank you for your continued support.

Motaquip Product Support

*Responsibility cannot be accepted for errors, omissions and other inaccuracies in this document though all contents were prepared carefully. This publication does not form or constitute part of any contract.
All rights reserved to change price, specification, design, quality or description of any product without previous notice.*